

The tying machine for all kinds of coiled bundles with vertical needle direction

The versatility of our twine tyers is almost unlimited: all kinds of cable and hose coils, V-belts, gaskets as well as bicycle tyres.

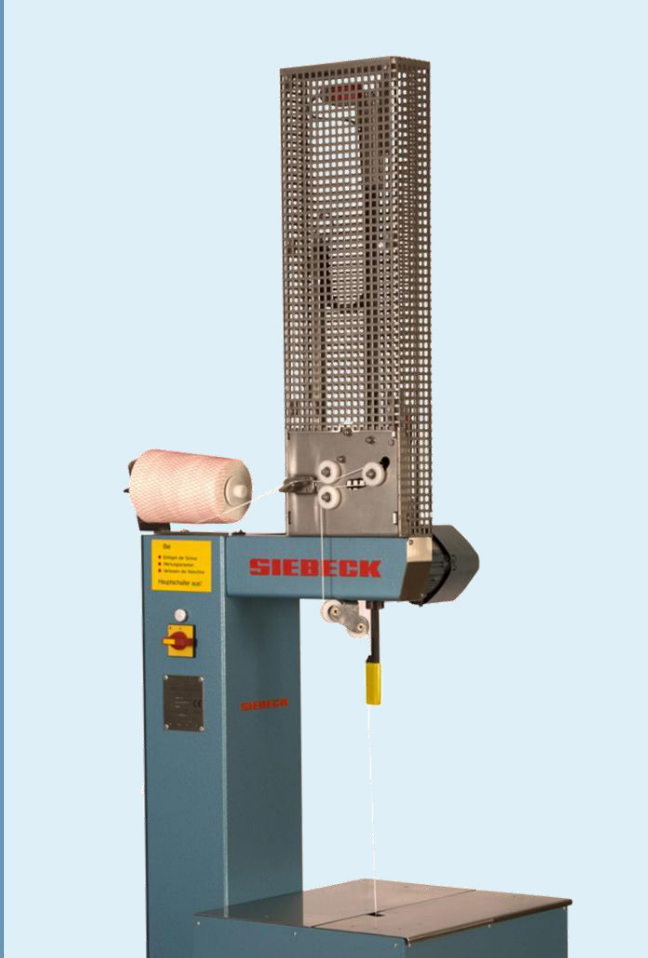

JET-IN RING BINDING MACHINE





RING BINDING MACHINE

Technical data

Machinery dimensions

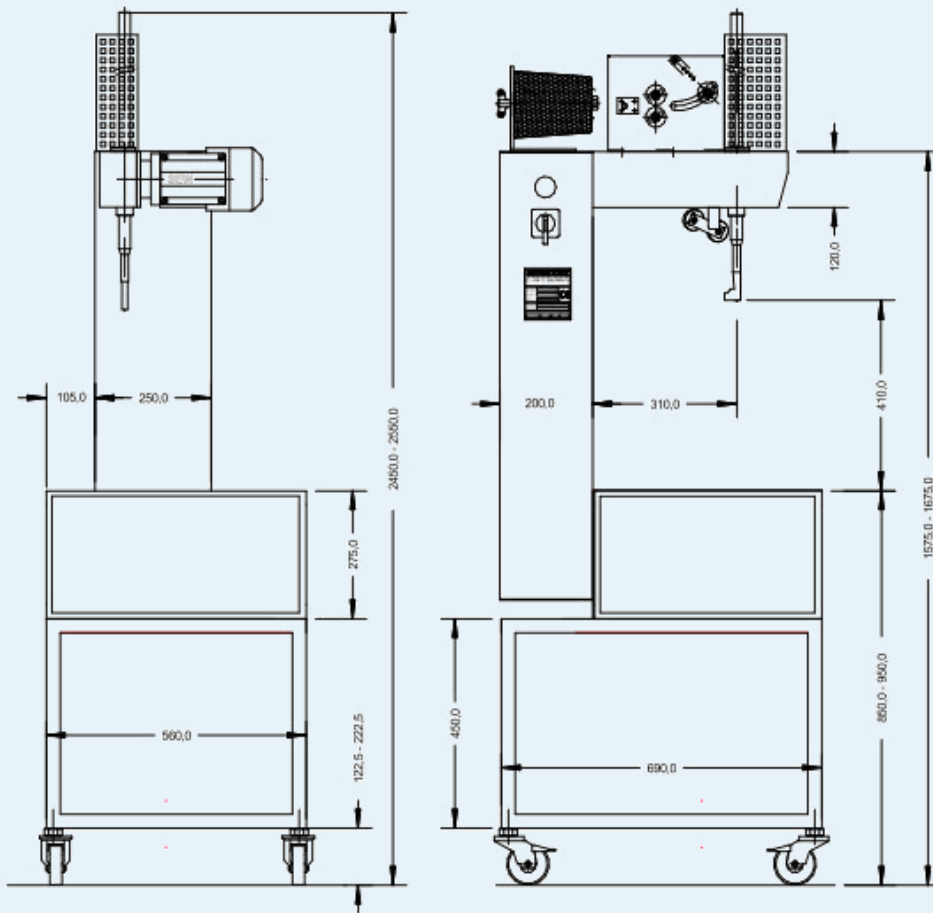

All dims. in mm, changes reserved

Electrical connection values: 400 Volt, 3 phase power supply, 1 kW, 50 Hz
Machine performance: up to 40 cycles p. min. (based on product size)
Machine weight: 130 kg
Noise pressure level: < 79 dB(A) as per EN 11204 (without product / without string)

Proper use:
 Solely commercial / strapping of preferably ring-shaped products

RING DIMENSIONS

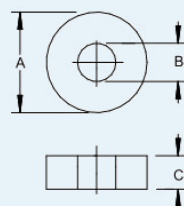

	maximal	minimal
A	600 mm	80 mm
B	500 mm	70 mm
C	400 mm	5 mm